

# Installation, Operating & Maintenance Manual

(Original Instructions)

**DRUM**

## BULKLINE SCREW COMPRESSOR

### Models

650

1000



T-BA-4000/4050-3  
September 2013

**Contents**

<b>Foreword</b> .....	<b>3</b>	6.1	Operation of the Screw Compressor .....	18	
1	Technical Data .....	4	6.2	Regular Inspections During Operation .....	18
1.1	Machine Data .....	4	6.2.1	Pressure, speed and temperature check.....	18
1.2	Dimensions Bulkline 650 .....	5	6.2.2	Safety Valve check .....	18
1.3	Dimensions Bulkline 1000 .....	6	6.2.3	Oil Pressure Gauge .....	18
1.4	Mode of Operation, Lubrication, Direction of Rotation .....	6	6.2.4	Oil Level.....	18
1.4.1	Mode of Operation.....	6	6.2.5	Air Filter .....	18
1.4.2	Lubrication.....	6	6.2.6	Permitted Tilt During Operation .....	18
1.4.3	Direction of Rotation.....	6	6.3	Inspection Intervals.....	19
2	Safety Instructions and Hazard Alerts.....	7	6.4	Measures for Prolonged Shutdown .....	19
2.1	Intended Use .....	7	7	Maintenance.....	20
2.2	Acceptance and Monitoring.....	7	7.1	Warranty .....	20
2.3	Hazard Alerts.....	7	7.2	Maintenance, Maintenance Schedule .....	20
2.4	Safe Working.....	7	7.3	Oil Change.....	21
3	Transport.....	9	7.4	Intake Air Filter .....	21
3.1	Transport .....	9	7.5	Combination Air Filter .....	21
3.2	Storage.....	9	7.6	Compressed Air Re-cooler .....	21
3.3	Delivery Scope .....	9	7.7	Cleaning .....	21
4	Installation.....	10	8	Troubleshooting and Remedy .....	22
4.1	Erection .....	11	8.1	Possible Operating Error .....	22
4.1.1	Intake Line / Discharge Line .....	11	8.2	Remedial Action .....	22
4.2	Installation of Compressor Components, Safety and Monitoring Equipment .....	12			
4.2.1	Air Filter .....	12			
4.2.2	Noise Control.....	13			
4.2.3	Non-return Valve .....	13			
4.2.4	Thermometer .....	13			
4.2.5	Pressure Gauge .....	13			
4.2.6	Safety Valve .....	13			
4.2.7	Hand Guard.....	13			
4.2.8	Retaining System for Conveyed Material .....	14			
4.2.9	Speed Control .....	14			
4.2.10	Oil Pressure Monitor.....	14			
4.3	Cooling .....	14			
4.3.1	Cooling .....	14			
4.3.2	Compressed Air Re-cooling .....	14			
4.4	Drive .....	14			
4.4.1	Drive by Flexible Coupling.....	14			
4.4.2	Drive by Hydro Motor .....	14			
4.4.3	Drive by V-belt.....	14			
5	Start-up .....	16			
5.1	System Checks .....	16			
5.2	Oil Lubrication .....	16			
5.2.1	Oil Filling.....	16			
5.2.2	Oil Level Inspection .....	16			
5.3	Stop Valve and Other Valves .....	16			
5.4	Direction of Rotation.....	16			
5.5	Turning On, Speed Check, Compression Discharge Pressure and Oil Pressure .....	16			
5.5.1	Speed .....	16			
5.5.2	Discharge Pressure.....	16			
5.5.3	Oil Pressure.....	17			
5.6	Removal of Preserving Chemical .....	17			
6	Operation .....	18			

**Dear customer,**

your new Screw Compressor is the outcome of intensive development based on decades of experience as a supplier of vacuum pumps and compressors. Advanced manufacturing methods in combination with highest quality standards and extensive testing ensure reliability, a high degree of availability and long life of your machine.

You will appreciate that this machine requires expert attention, especially in severe service environments. Start-up, operation and maintenance therefore require trained and authorised personnel.

These Operating Instructions contain all required information and have been written for those in charge of the compressor. The machine will give smooth service for a long time provided these instructions are followed. The Operating Instructions are a component part of the product and must be kept available for the operating personnel. We cannot be held responsible for any damage caused due to non-compliance with these instructions.

Please note that repairs should only be undertaken by authorised repair centres using original parts. Otherwise our guarantee will be void.

We wish you success with your screw compressor from Gardner Denver. If you have any questions for which you do not find an answer in this booklet, please call us.

Sincerely yours,

Gardner Denver Drum Ltd.

**Note on references to illustrations**

The first digit of the references to illustrations in these Operating Instructions refers to the chapter in which you find the illustration. The illustrations within each chapter are numbered consecutively. The last number of an illustration reference denotes the position number of the item in the references illustration.

For example, the reference (7.2 / 3): second illustration in chapter 7, item number 3.

# 1 Technical Data

## 1.1 Machine Data

Screw compressors of the Bulkline series are contactless screw compressors. The air is compressed in dry state.

The name plate of the machine contains important data in addition to the machine number.

### Technical Data of the Bulkline series

	Unit	Bulkline 650			Bulkline 1000		
Drive speed <sup>1)</sup>	rpm	2,400	3,000	3,600	2,400	3,000	3,600
Intake pressure (absolute)	bar	1	1	1	1	1	1
Intake temperature	°C	20	20	20	20	20	20
Discharge temperature at working gauge pressure of 2.0 bar and 20 °C intake temperature <sup>2)</sup>	°C	185	181	179	185	181	179
Max. permitted intake temperature	°C	40	40	40	40	40	40
Working gauge pressure	barg	2.0	2.0	2.0	2.0	2.0	2.0
Maximum gauge pressure <sup>3)</sup>	barg	2.5	2.5	2.5	2.5	2.5	2.5
Delivery at operating gauge pressure: 0 barg 2.0 barg 2.5 barg	m <sup>3</sup> /h	400 365 350	520 464 455	630 580 560	640 565 550	825 740 720	1025 945 925
Coupling power at gauge pressure: 2.0 barg 2.5 barg	kW	23 25	28.5 35	35 40	32.5 36.0	45.5 51.0	54.0 61.5 <sup>4)</sup>
Minimum power of electric drive motor at gauge pressure of 2.0 bar	kW	30	30	37	37	55	55 <sup>5)</sup>
Maximum running time in continuous service <sup>6)</sup> (without installed cooler)	h	3	3	3	3	3	3
Mass moment of inertia at the drive shaft	kgm <sup>2</sup>	0.23	0.23	0.23	0.30	0.30	0.30
Noise level at 1 m distance at 1.5 bar gauge	dB(A)	87	89	92	87	89	92
Compressor weight without accessories	kg	117	117	117	127	127	127

1) The permitted drive speed range from 2,400 rpm to 3,600 rpm must be observed.

2) Values relate to pressure loss free intake and exhaustion

3) Provide safety valve

4) On demand

5) Drive speed: max. 3,500 rpm

6) at max. working gauge pressure of 2.0 bar (an oil cooler must be provided for extended continuous service)

## 1.2 Dimensions Bulcline 650

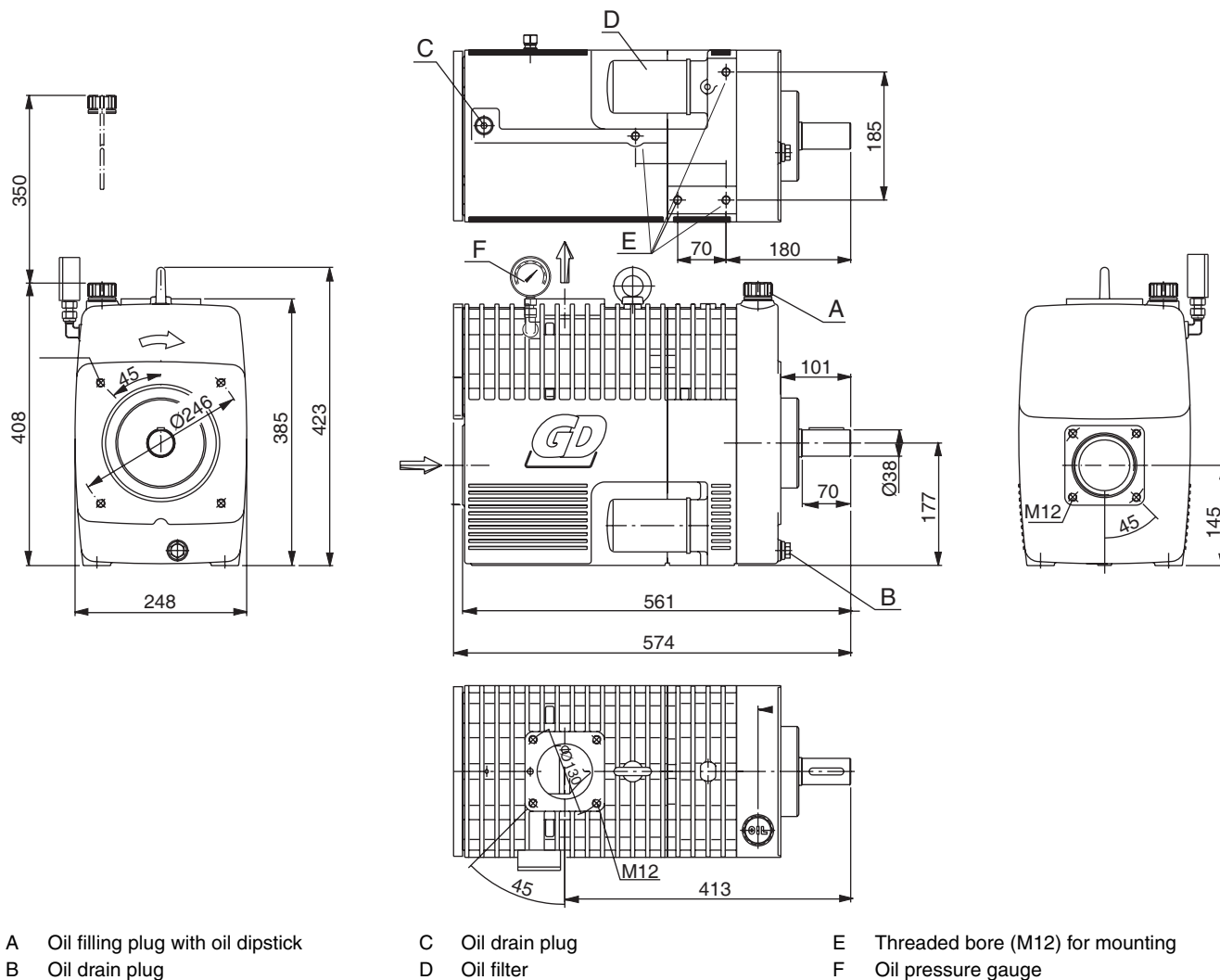

Fig. 1.1 Bulcline 650 Dimensions



### Variants Bulcline 650

Machines with serial numbers 915 830/... have M10 thread for connection to the intake and delivery lines. The oil drain in the screw casing (Figure 1.1/C) is not available on these machines. Three M12 threaded bores are provided for mounting.

### 1.3 Dimensions Bulcline 1000

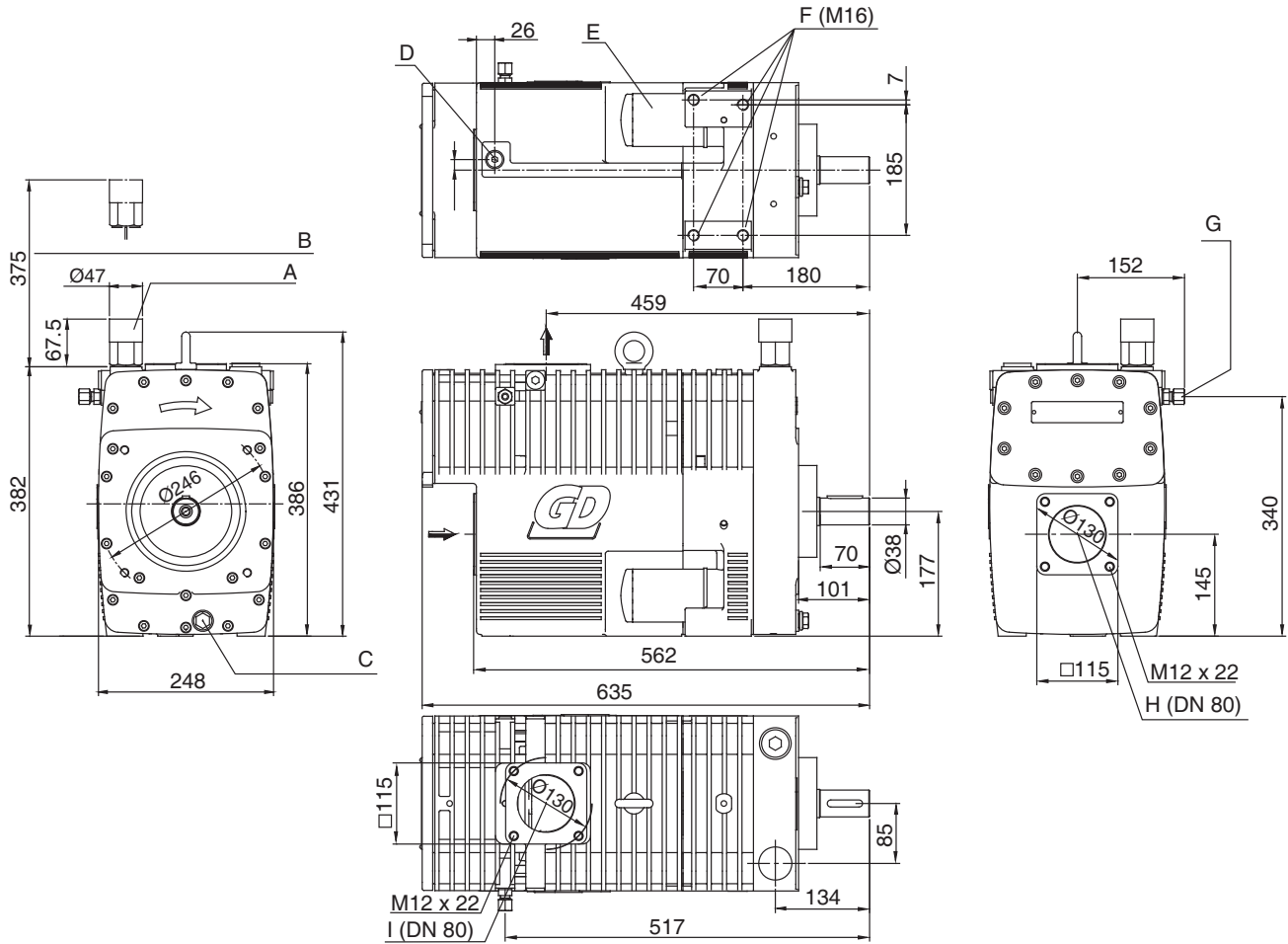

- |                                      |   |                                     |
|--------------------------------------|---|-------------------------------------|
| A Oil filling plug with oil dipstick | D Oil drain plug G 3/8"                   | G Connection for oil pressure gauge |
| B Needed space for oil filling plug  | E Oil filter                              | H Inlet flange                      |
| C Oil drain plug G 1/2"              | F Threaded bore (4 x M16-27) for mounting | I Outlet flange                     |

Fig. 1.2 Bulcline 1000 Dimensions

### 1.4 Mode of Operation, Lubrication, Direction of Rotation

#### 1.4.1 Mode of Operation

Screw compressors operate on the displacement principle and belong to the group of multiple-shaft displacement machines.

Two rotors are mounted in the machine casing parallel to each other. The two rotors, i.e. main rotor and secondary rotor, have screw profiles specially for the compression process. The screw profiles of the main rotor and secondary rotor generate cavities inside the machine casing without contacting each other.

During the intake stage the cavities increase continuously. Air is drawn into the rotor cavity. The intake process is completed when the cavity reaches maximum size. The air on the opposite side is compressed

polytropically by the reducing cavities as rotation continues.

#### 1.4.2 Lubrication

Bearings and gears are lubricated by forced-feed lubrication with integrated oil pump and oil filter.

#### 1.4.3 Direction of Rotation

The screw compressor rotates clockwise when looking at the drive shaft (see arrowed direction on the machine).

## 2 Safety Instructions and Hazard Alerts

The screw compressor is a state-of-the-art product built in compliance with all generally accepted safety standards. Despite this the machine in use can be a hazard to the lives of the users or other persons or cause loss and damage to the machine and other objects.

It is therefore important to read these Operating Instructions and observe all safety instructions. Supplier will not be liable for any damage due to unauthorized use or use for purposes other than intended.

### 2.1 Intended Use

The intended purpose of the screw compressor is to convey and compress filtered air. Any use other than or beyond that described above is not intended.

Adherence to the operating instructions and the specified maintenance is also part of the intended purpose.

### 2.2 Acceptance and Monitoring

The screw compressor is not subject to any acceptance or monitoring requirements.

Where special regulations apply at the place of use of the compressor, the operator is responsible for complying with these regulations.

The safety and accident prevention regulations of the local employer's association must be followed.

### 2.3 Hazard Alerts



This symbol indicates potential hazards which will cause personal injury if the warning is ignored. Safety instructions must be known to all users!



“CAUTION” indicates directives and provisions which must be followed to avoid damage to the machine.



This symbol indicates important information for the user of the machine.



This symbol indicates that environmental provisions must be observed.



This symbol indicates a hot surface. Risk of burns!

### 2.4 Safe Working



Any person deployed on the machine shall read the Operating Instructions, especially the safety instructions, before beginning to work.

- Work on electrical equipment shall be carried out by a trained electrician in accordance with the rules of the trade.
- Carry out work, including maintenance and repairs, on the machine only when it is not running.
- Before beginning work, secure the machine against start.
- Relieve the machine to atmospheric before beginning to work.
- On the truck: Close the stop valve. Depressurize or vent the line between the unit and the stop valve.
- Relieve overpressure manually on the safety valve.
- Take the pressure gauge reading.
- Remove drive guards only when the machine is not running.
- Remove the hand guard only when the machine and the discharge line have cooled down.
- Before starting the machine, make sure that all guards are properly installed.
- Intake line and discharge line must be installed when operating the compressor.
- Changes, attachments or modifications to the machine which are likely to effect the safe operation shall not be made unless after prior consultation of the manufacturer.
- Observe all warnings on the screw compressor. Warnings must always be legible. No warning shall be removed or defaced.
- Observe fire alarms and fire fighting instructions.
- Use the screw compressor only in good technical condition. Use it only to transport air, and observe all safety precautions. In particular, any fault effecting the safe operation of the machine shall be repaired without delay.

- These Operating Instructions must be stored on or near the machine.



Environmental protection requires that all draining fluids, such as cooling water, oil, lubricant, are collected and disposed of as prescribed by law.



## 3 Transport

Symbols on the package



Top



Fragile



Keep dry

### 3.1 Transport

Do not use force when transporting the screw compressor. Handle the machine with care. Attach the machine only on the securely mounted lifting screw.

Remove all transport guards.

### 3.2 Storage



Store the machine in a dry room at above-zero temperature. Remove the blind covers on the intake and delivery sockets only just before the machine is installed. If the screw compressor is stored or not used for an extended period of time, it must be preserved to protect it from corrosion. Consult the manufacturer for the right preserving compound.

### 3.3 Delivery Scope

When the consignment arrives, check the consignment note for short delivered or damaged items. If damage is found or any items are short-delivered, register a written claim with the carrier.

## 4 Installation

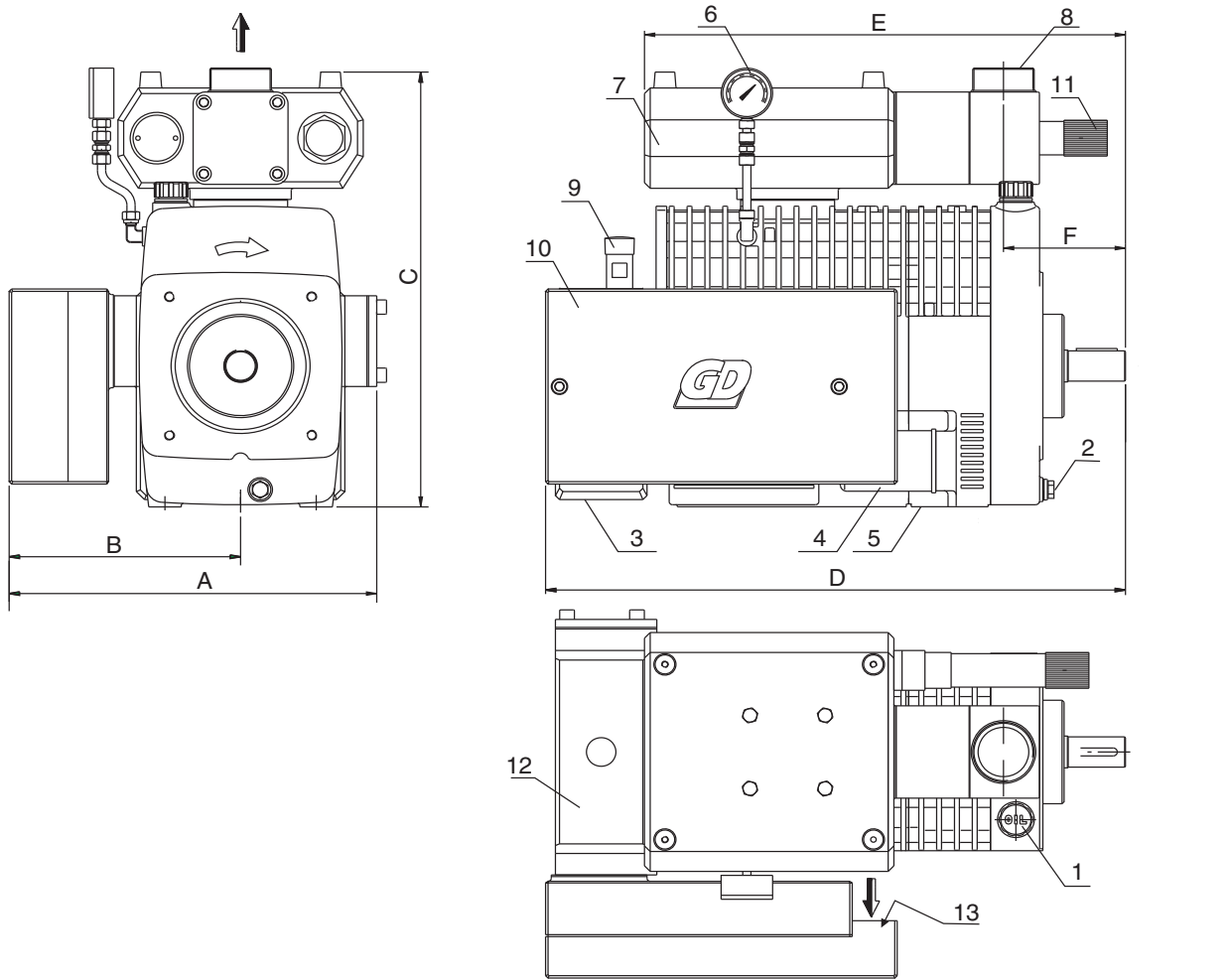

- |                                      |   |  |                         |
|--------------------------------------|---|--|-------------------------|
| 1 Oil filling plug with oil dipstick | 5 Threaded bores for erection (4 x M12) | 8 Compressed air outlet G2 <sup>1</sup> / <sub>2</sub> " | 10 Intake air filter    |
| 2 Oil drain plug                     | 6 Oil pressure gauge                    | 9 Air filter maintenance indicator                       | 11 Safety valve         |
| 3 Oil drain plug                     | 7 Discharge line silencer               |  | 12 Intake line silencer |
| 4 Oil filter                         |   |  | 13 Intake air inlet     |

Fig. 4.1 Layout (example with original accessories)

Dimensions	A	B	C	D	E	F
Bulkline 650	450	283	546	709	588	149
Bulkline 1000	635	469	598	682	523	98

Figure 4.1 illustrates the example of a completely installed Bulkline screw compressor with accessories from Gardner Denver. The accessories are optimal matches to the rating of the compressor.



**Warning!**

The screw compressor must only be installed and started up by trained personnel. When the machine is transported, attach it only on the securely mounted lifting screws. Damage due to improper handling is not covered by manufacturer's liability. The machine is delivered as a complete unit fully assembled. The machine must not be damaged in transit. Make sure that the drive shaft rotates freely; if you have to use force to rotate the shaft, inform our customer service staff.

For erection and installation the screw compressor, proceed as follows:

- Install the screw compressor and mount the intake and delivery lines.
- Install the safety and monitoring equipment.
- Connect the screw compressor to the drive unit.
- These activities are described in detail below.

**4.1 Erection**

The screw compressor must be set up with the machine feet down. The location on the truck where the compressor is installed:

- must be easy to access,
- must be protected from dust, flying stones and splash water,
- must allow sufficient space for the installation of the discharge and intake lines,
- the oil filter and the oil filling necks must be accessible for maintenance,
- indicating instruments and safety accessories must be easy to read and access.

The screw compressor must be mounted with the drive shaft horizontal and the compressor in upright position. The permitted deviation from the horizontal line is max. 10°. (In addition to this, if the compressor is mounted on a truck, consider that the truck may be standing at a gradient.)

The screw compressor is mounted with 4 screws (for size, see table below), respectively, which are installed in the threaded bores on the underside of the compressor. The screws must be secured against coming lose. The screws must be installed to the prescribed depth.

Commonly the machine is mounted on the truck frame with a bracket.



Consider that the truck may be at a gradient.

Type of screw	Tightening torque (for lubricated screwed connections)	Screw running depth
M16-8.8	190 Nm	22 - 24 mm

The mounting bracket must be suitable to support the weight of the screw compressor and take up the compressor's service loads.

The mounting points must not be at different levels. Make sure that no stress is introduced in the screw compressor from mounting.

The mounting points must be in exact alignment, i.e., they must be in one plane.

For dimensions and weights, see chapter 1 "Technical Data".



The machine must be adequately earthed. An equipotential earth bonding strap should be securely fastened between the machine body and a suitable point on the vehicle frame.

Ensure that the machine and all ancillaries are earthed in accordance with BS5958 Pt1: 1991;

'Control of undesirable Static Electricity'.

**4.1.1 Intake Line / Discharge Line**

The screw compressor can only be operated with connected intake and discharge lines. For connection dimensions of the intake and discharge lines, refer to standard DIN 28461.



**Caution!**

The connected discharge line must not introduce any mechanical stress in the discharge flange of the machine.

Make sure that the discharge line is connected so that no stress occurs. Consider stress can also be produced during the operation and by the temperature of the compressor.

Use lines of sufficient diameter. For minimum diameter, refer to the table below.

## Installation

Use pipe of the minimum diameter in the following table.

Connection	Required minimum diameter
Intake line	DN 80
Discharge line	DN 80



If pipes of wrong diameter are used, Gardner Denver is relieved of any liability for damage or loss of the machine.

Use pipe which is corrosion-resistant inside. Clean the pipe inside before installation. Remove welding beads, scale and rust carefully.

As an extra safeguard we recommend to install a screen (1 mm mesh) directly upstream the intake flange for the first few days of compressor service.

The intake line must be installed at an upward gradient towards the machine to prevent inflow of condensate.

The discharge line must be installed at a downward gradient from the machine. A condensate trap must be installed at the lowest point of the pipeline.

## 4.2 Installation of Compressor Components, Safety and Monitoring Equipment

The following components ensure smooth operation of the machine:

- Intake side:
  - Air filter
  - Intake silencer
- Delivery side:
  - Delivery silencer
  - Non-return valve
  - Thermometer (optional)
  - Pressure gauge (optional)
  - Safety Valve
- Hand guard on rotating and hot parts
- Speed control (optional)
- Maintenance indicator for the air filter
- Retaining system for conveyed materials
- Oil pressure monitor



All warranty claims on Gardner Denver are forfeited in case of non-compliance.

### 4.2.1 Air Filter

The air filter removes particles from the intake air. The air filter should be installed to avoid damage to the screw compressor from solid particles entrained in the air. Gardner Denver supplies two different versions of the air filter:

- Air intake through the intake filter for direct mounting on the machine (for part no., see special Spare Part List).
- Air intake through combination dry air filter using hose or pipe connection for remote installation away from the compressor (for part no., see special Spare Part List).

If the combination filter from Gardner Denver is used, the filter must be supported on the intake side (see Fig. 4.2/3).

The filter must only be installed horizontally (Fig. 4.2).

The intake filter must be protected from splash water, rain, exhaust fumes and engine heat.

#### Maintenance Indicators

The air filter has an visual maintenance indicator. It indicates the degree of filling of the filter cartridge (see Fig. 4.2/5).

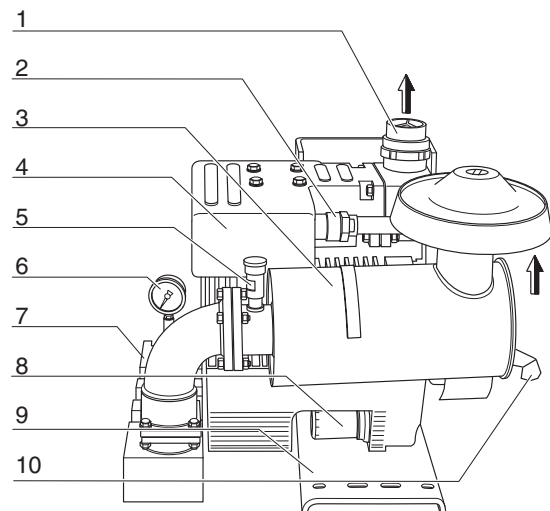

- |                             |                                    |
|-----------------------------|------------------------------------|
| 1 Compressed air connection | 5 Air filter maintenance indicator |
| 2 Safety valve              | 6 Pressure gauge                   |
| 3 Combination air filter    | 7 Intake line silencer             |
| 4 Discharge line silencer   | 8 Oil filter                       |
|                             | 9 Mounting bracket                 |

Fig. 4.2 Compressor with mounted combination air filter

When mounting the filter:

- observe the flow direction of the intake air;
- leave space for changing the filter insert;
- check for leaks of the intake line to the machine.

#### 4.2.2 Noise Control

The principle of screw compression generates noise due to high-frequency vibration from the high rotating speed of the compressor. It is recommended to install silencers in the intake line and the discharge line.

##### Intake Line Silencer

The intake line silencer reduces the high-frequency intake noise (for part no., see special Spare Part List).

##### Discharge Line Silencer

The discharge line silencer reduces high-frequency noise in the discharge line system. The discharge line silencer also has a safety valve (for part no., see special Spare Part List).

#### 4.2.3 Non-return Valve

The non-return valve avoids rotation in opposite direction when the machine is turned off. The non-return valve should be mounted directly on the compressor. The non-return valve cannot stop the flow of goods.

A non-return valve is integrated in the Gardner Denver discharge silencer.

If a different discharge silencer is used it must ensure that the compressor is used with a non-return valve.

#### 4.2.4 Thermometer

The thermometer which monitors the temperature of the compressed gas must be mounted in the discharge line. If the conveyed medium contains flammable material it must be ensured that the temperature of the compressed gas remains lower than the self-ignition temperature of the flammable dust/air mixture. A gas cooler must be mounted in the system if necessary.



The thermometer must measure temperatures between 0 ... 250 °C. Observe all national regulations regarding this item.

#### 4.2.5 Pressure Gauge

To provide constant information on the compressed air pressure, a compressed air pressure gauge should be integrated in the system. The pressure gauge must measure pressure in the operating pressure range of

the compressor. The pressure gauge is mounted directly downstream the discharge port.

#### 4.2.6 Safety Valve

In accordance with the applicable safety regulations, a non-lockable safety valve must be fitted downstream of every compressor.

The size and setting of the safety valve must be selected so that the maximum permitted operating pressure cannot be exceeded by more than 10%. The safety valve must be able to blow off the whole volume of air supplied by the screw compressor.

Observe the following for mounting the safety valve:

- Mount the valve directly downstream the screw compressor, upstream any other shutoff fitting (in particular, any shutoff valve).
- Make sure that the component marking and the safety seal are present.
- The valve must be set to the maximum permitted operating pressure (see chapter 1.1 "Machine Data"),
- The setting must be secured against unauthorized changes.
- The valve must not be blocked.
- Do not use the safety valve to control the rate of compressed air delivery.



Make a weekly manual function check of the safety valve when the compressor is running.

#### 4.2.7 Hand Guard



The design of the machine must make it impossible to touch rotating or reciprocating parts of the machine with the hands.



Besides, precautions must be taken to touch hot parts (discharge line, discharge line silencer) with the hands.

Suitable hand guards must be included in the design of the system.

In Line with the applicable accident prevention regulations the surface temperature must not exceed 80°C.

### 4.2.8 Retaining System for Conveyed Material

The construction of the silo shall ensure that the discharge line is free from conveyed material in all operating conditions.

This is possible, for example, if a second non-return valve is mounted directly upstream the material feeding point.

### 4.2.9 Speed Control

Speed control on the machine and speed indicator on the operator console are recommended.

For permitted drive speed ranges, see chapter 4.4 Drive.

### 4.2.10 Oil Pressure Monitor

It is recommended to mount an oil pressure gauge to monitor the oil pressure of the screw compressor.

The oil pressure must not drop below 0.5 bar (see chapter 8 "Troubleshooting and Remedy").

## 4.3 Cooling

### 4.3.1 Cooling

No cooling is required in normal service conditions. Cooling is not necessary if the compressor is not running for more than 3 hours at full load without enclosure.

When the compressor runs for more than 3 h or in a severe environment or in an enclosure, additional cooling by oil cooler is necessary. Consult Gardner Denver before you mount the oil cooler.

### 4.3.2 Compressed Air Re-cooling

A compressed-air cooler is recommended for screw compressor from Gardner Denver to reduce the temperature of the compressed air. The temperature limits of accident prevention regulations UVV 16 should be observed. Please observe all national regulations regarding this item.

Compressed-air re-coolers matching the screw compressor rating are available as accessories.

## 4.4 Drive



Note the rotation arrow on the casing of the screw compressor.

Permitted drive speed range of the screw compressor: 2,400 to 3,600 rpm.



Please note the step-up or step-down ratio of the transmission (V-belt drive, truck p.t.o., etc.).

If no continuous speed control is provided, the speed should be checked after mounting the screw compressor and a note to the operator should be put up on the truck.

If the compressor is powered by a combustion engine, a speed limiter must be installed which ensures that the compressor cannot run at higher than permitted maximum speed if the load drops.

The following drive versions of the screw compressor are available:

- by V-belt, the belt pulley is mounted on the free shaft end;
- diesel engine or electric motor by V-belt;
- hydro motor directly by flexible clutch;
- electric motor, direct drive (after consultation with us).

### 4.4.1 Drive by Flexible Coupling

If the compressor is coupled directly to the drive unit (e.g., a diesel engine), a torsionally flexible coupling as specified by the supplier must be used which compensates most of the cyclic irregularity of the drive.



Align the coupling exactly as described by the manufacturer.

### 4.4.2 Drive by Hydro Motor

Selection and mounting of the hydro motor is the responsibility of the erector. A suitable mounting flange and the clutch can be supplied by Gardner Denver (see list of accessories).

The compressor-side half clutch is already mounted in the factory. The half clutch on the engine/motor side must not introduce stress in the screw compressor after connection to the mounting flange.

### 4.4.3 Drive by V-belt

If the speed of the screw compressor must be stepped up or down, a V-belt drive should be used. The permitted drive speed range must be observed (see chapter 1 "Technical Data").

The belt pulleys in the table below can be mounted directly on the free shaft stud of the screw compressor.

Bulkline 650 Belt profile		SPA		XPA
		mm	140	125
Smallest pulley diameter $D_{Wmin}$	mm	140	125	125
Number of belts		4	5	4

Bulkline 1000 Belt profile		XPA		SPA
		mm	160	180
Smallest pulley diameter $D_{Wmin}$	mm	160	180	180
Number of belts		5	4	5

**Mounting the V-belt Drive**

- To ensure uniformity of V-belt tension, replace all V-belts as a set.
- Make sure of exactly parallel alignment of the axes in the plane of the driving and driven shafts.
- The grooves of the belt pulleys must not be offset.
- Set the V-belt tension as prescribed by the manufacturer.

**Mounting Taper Lock Belt Pulleys**

1. Clean and remove grease from the unprotected metal surface. Insert sleeve in pulley. Align bores and mount screws loosely (4.3.1).
2. Push the pulley and sleeve on the shaft, align and tighten screws uniformly (4.3.2).

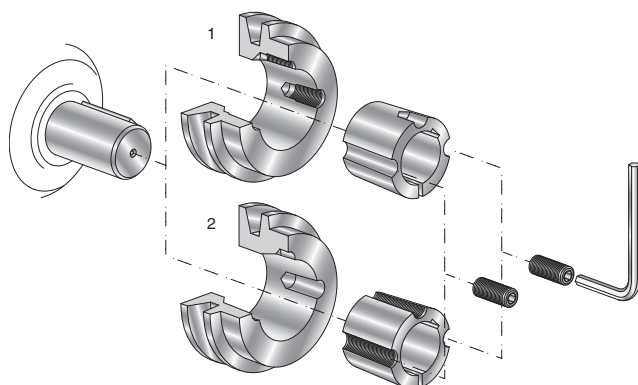

Fig. 4.3 Mounting V-belt pulley with taper lock

**Removal**

1. Pull out screws, install one screws as forcing screw in the hole with half thread in the sleeve and tighten the screw. This causes the taper lock sleeve to come off.
2. Take up the pulley assembly with your hands without using a hammer or damaging the machine.

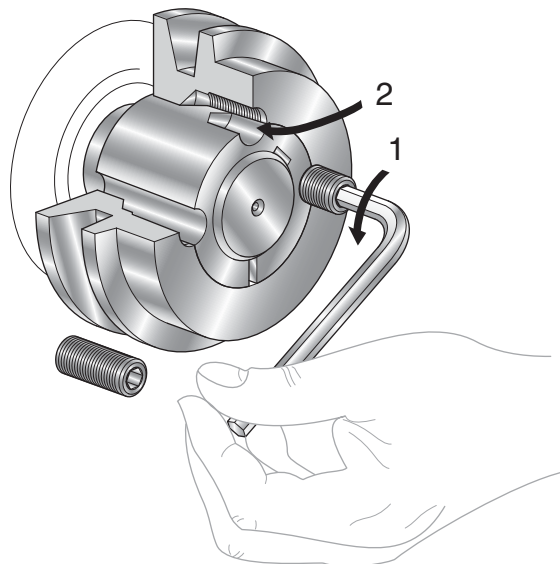

Fig. 4.4 Removing the V-belt pulleys

## 5 Start-up

### 5.1 System Checks

The first start-up and also the start-up of the compressor after an extended period of shutdown (over 4 weeks) are critical to the optimal function of the machine.



Proceed slowly and with care. Do not skip any steps. Damage due to wrong start-up is not covered by warranty.

#### Prior Start-up

Proceed as follows:

- Inspect the screw compressor for damage in transit, wrong erection, etc.
- Make sure that the hand guards are installed (rotating and hot parts).
- Instruct the operator in the operation and maintenance of the machine and store the instruction manual near the machine.
- Try to turn the driving shaft by hand. The shaft should turn freely.

### 5.2 Oil Lubrication

#### 5.2.1 Oil Filling

Fill sufficient oil as specified in the lubricating recommendation of the screw compressor. The oil volume is 8 liters when the compressor is placed horizontally.

Recommended lubricants, see chapter 7 "Maintenance".

#### 5.2.2 Oil Level Inspection

Inspect the oil volume in the screw compressor.

The oil level should be checked every week. The oil level must be between the MAX and MIN marks on the oil dipstick. The MAX mark corresponds to about 8 liters oil. The difference between MAX and MIN is 3 liters.



The oil level must be between the MIN and MAX marks on the oil dipstick. Oil levels below or above the oil dipstick marks can damage the screw compressor.

Caution: Do not overfill.



Dispose of oil, grease, cleaner or components such as, e.g., filter cartridges, as prescribed by environmental laws.

### 5.3 Stop Valve and Other Valves

If a commercial non-return valve is mounted in the discharge line, inspect for correct direction (arrow on valve housing).

Open all manual shutoff valves.



The screw compressor must not be used as vacuum pump.

The stop valves in the discharge line must not be closed. Closed valve can cause failure of the compressor.

### 5.4 Direction of Rotation

Briefly turn on the drive to make sure of correct rotation. The screw compressor rotates clockwise when looking at the drive shaft (see arrowed direction on the machine).

Engage the drive softly.

### 5.5 Turning On, Speed Check, Compression Discharge Pressure and Oil Pressure

Turn on the drive and observe pressure building up in the compressor.



Do not start the screw compressor when the system is pressurized.

#### 5.5.1 Speed

Permitted operating speed range: 2,400 – 3,600 rpm.

#### 5.5.2 Discharge Pressure

The discharge gauge pressure is 2.0 bar. The maximum gauge pressure is 2.5 bar.

A non-shutoff safety valve should be located downstream of the compressor. The safety valve must be suitable and ensure that the maximum permitted operating pressure of 2.5 bar gauge cannot be exceeded by more than 10%.

Please observe all national regulations regarding this item.





Check to make sure that the safety valve opens at 2.5 bar gauge and blows off at maximum 2.7 bar gauge pressure.



Improper setup or installation of the compressor or manipulation of the safety valve cause pressure and temperature rise with risk of machine failure.

### 5.5.3 Oil Pressure

Check the oil pressure gauge to make sure that oil pressure builds up in the system. When the system is at operating temperature, the oil pressure with a new filter is >1 bar. This pressure must be present when the compressor is running at speed as specified in chapter 1.1. The oil pressure must not be lower than 0.5 bar.

## 5.6 Removal of Preserving Chemical

To avoid corrosion attack the rotors are preserved with preservation compound. We recommend a brief trial operation before starting regular service.

- Duration of trial operation: 20 min
- Operating state: 2 bar gauge
- Speed: 2,400 – 3,600 rpm



Engage the screw compressor softly (see also chapter 5.4 "Direction of Rotation").

## 6 Operation

Start the screw compressor as described in chapter 5.



Damage caused by wrong start-up is not covered by warranty.

### 6.1 Operation of the Screw Compressor

The compressor is designed for intermittent service. If the compressor is running for more than 3 hours, an additional external oil cooler is necessary.

### 6.2 Regular Inspections During Operation

#### 6.2.1 Pressure, speed and temperature check

Check the working pressure, speed and discharge temperature according to chapter 1.1 "Machine Data".

#### Drain Condensate

Drain condensate regularly on compressors with compressed air re-cooler.



The vessel must not be pressurized when condensate drains. There is risk of freezing in winter.

#### 6.2.2 Safety Valve check

A non-shutoff safety valve should be located in the discharge line downstream of the compressor. The safety valve must be suitable and ensure that the maximum permitted operating pressure of 2.5 bar gauge cannot be exceeded by more than 10 %.

Please observe all national regulations regarding this item.



#### Warning!

The setting of the valve must be secured from unauthorized or accidental change. The safety valve must not be blocked or tampered with.



#### Warning!

The safety valve must not be used to control pressure.

Make a manual function check of the safety valve at start-up and then ever weekly, when the compressor is running.



#### Warning!

The emitted compressed air is hot. Risk of scalding.

### 6.2.3 Oil Pressure Gauge

Check the oil pressure on the oil pressure gauge. The oil pressure must not drop below 0.5 bar. If the oil pressure drops below 0.5 bar, the oil filter just be changed as described in chapter 7 "Maintenance".

### 6.2.4 Oil Level

Check the oil level in the screw compressor with the oil dipstick. Fully insert the oil dipstick. The oil level must be between the **min** and **max** marks on the dipstick.

The **max** mark corresponds to about 8 liters oil with the compressor in horizontal position. Do not overfill. Check the oil level every day. The difference between **MAX** and **MIN** is 3 liters.

Recommended oil grade: see chapter 7.3 "Oil Change".

### 6.2.5 Air Filter

Check to ensure if the maintenance indicator is in the permitted range.

The filter must be changed when the read sector is reached.

If an scale indicator is used, the filter element must be changed when the indicator shows 60 mbar vacuum.

### 6.2.6 Permitted Tilt During Operation

The maximum permitted tilt in longitudinal or transversal direction of the compressor axis is 10° on the horizontal line. Note that the truck on which the compressor is mounted may be parked on a gradient.



Tilt over 10° causes damage to the compressor.

### 6.3 Inspection Intervals

	Value	Every 10 – 20 min when running	After every use	Daily	Weekly	See chapter
Operating speed	2,400 to 3,600 rpm	<b>x</b>				1.1
Operating gauge pressure	2.0 bar	<b>x</b>				1.1
Air outlet temperature at 20°C intake temperature	185 °C	<b>x</b>				1.1
Drain condensate (e.g., on air re-cooler)			<b>x</b>			6.2.1
Inspect safety valve					<b>x</b>	6.2.2
Inspect/clean machine					<b>x</b>	7.2
Oil pressure	>0.5 bar	<b>x</b>				6.2.3
Oil level					<b>x</b>	6.2.4
Air filter maintenance indicator					<b>x</b>	6.2.5

### 6.4 Measures for Prolonged Shutdown

- Clean the screw compressor thoroughly.



If you clean with high pressure, water can enter the compressor and cause extensive damage and failure of the compressor.



If the truck-mounted compressor is not used for a period of over a month, we recommend to run the compressor at least for 15 minutes every month to avoid damage due to corrosion.

## 7 Maintenance

### 7.1 Warranty

We are sure you appreciate that we are not liable for damage caused by non-compliance with the installation and operating instructions.

Please note that repairs to the screw compressors must be carried out by an authorized repair center using original parts. Other wise no warranty is available.

### 7.2 Maintenance, Maintenance Schedule



Observe the safety instructions in chapter 2 for all maintenance work and inspections.

The screw compressor must be maintained by trained personnel.

The machine must not be running and the pressure in all lines must be relieved.

Failure or interruption of operation due to poor or improper maintenance can cause very high repair cost and long downtime of the machine. Regular maintenance is therefore a 'must'.

The maintenance intervals in the table below refer to intermittent operation of about 3 hours every day at 2 bar working gauge pressure.

Maintenance point	Action	See chapter	Maintenance interval			
			weekly	monthly	quarterly	half-yearly
Compressor	clean	7.7	x			
Air filter	inspect/change	7.4, 7.5	x			
Safety valve	inspect/actuate	6.2.2	x			
V-belt and V-belt tension	inspect/re-tension		x			
Non-return valve	inspect				x	
Oil level	inspect/add oil	6.2.4	x			
Oil change	change	7.3				x or every 500 h
Oil filter change	change					x or every 500 h
Cooling air duct with compressed-air re-cooler	inspect/clean	7.6	x			

## 7.3 Oil Change

Change the oil regularly after the specified interval. The machine is filled with 8 liters oil (when machine is horizontal).

We recommend the following oil grades:

Permitted are multi-range engine oils of specification: API CD and MIL L-2104 C/ or higher.

Viscosity class: SAE 10/W40 or SAE 15/W40

Permitted temperature range: -10 °C ... +35 °C.

Consult the manufacturer for other temperature ranges.

The following oil types are approved:

Manufacturer	Type
ARAL	Multi Turboral SAE 15W40
DEA	Coronos Super DX SAE 15W40
ESSO	Essolube XT 301 SAE 15W40
MOBIL	Mobil Universal FL SAE 10W40
FINA	Kappa FE SAE 10W40
SHELL	Rimula Ultra SAE 10W40

As operating conditions differ, no exact interval for maintenance, inspection or cleaning can be specified. The information in the table is only for orientation.



Install all guards removed for inspection or maintenance.



Dispose of oil, grease, cleaner or components such as, e.g., filter cartridges, as prescribed by environmental laws.

## 7.4 Intake Air Filter

See Figure 4.1.

Change the filter cartridge as follows:

- Install a 10 mm wrench on the hexagon socket screw and push in fully.
- Turn screw by 90°.
- Remove the filter insert and install new filter.
- Assemble filter in reverse order.

## 7.5 Combination Air Filter

See Figure 4.2.

Make a weekly check of the dust discharge valve (4.2/10) by compressing the valve to note dust collection.

The maintenance indicator indicates the state of the filter cartridge in the intake air filter.



The filter cartridge must be changed when the maintenance indicator shows red (4.2/5).

Change the filter cartridge as follows:

- Remove the wing nut and the casing cover.
- Remove the hex nut and pull out the filter cartridge.
- Wet-clean the filter casing, especially the contact face of the filter cartridge. Make sure that no foreign material enters the pipeline between the filter and the compressor.
- Install the combination filter with the new filter cartridge in reverse order. Mount the casing cover with the dust discharge valve down.
- After cleaning the filter, press in the hook-shaped pressure switch on the maintenance indicator (colour changes from red to colourless). The maintenance indicator is again ready for service.



It is possible to clean the filter cartridge once by blowing and tapping. Then the filter cartridge must be replaced on the next occasion.

## 7.6 Compressed Air Re-cooler

If the screw compressor is equipped with a compressed air re-cooler, inspect the cooling air inlet and outlet openings every week and clean away dust and dirt if necessary.

The cooling air passage must not be obstructed.



To ensure optimal cooling, the air must circulate freely. Contamination reduces the cooling effect.

## 7.7 Cleaning

- The screw compressor should be cleaned every week.



If you clean with high pressure, water can enter the compressor and cause extensive damage and failure of the compressor.

Run the machine warm for several minutes after wet cleaning to avoid corrosion due to moisture.

## 8 Troubleshooting and Remedy

### 8.1 Possible Operating Error

Operating errors can cause failure of the machine.



Failure due to operating error is not covered by the warranty available from Gardner Denver.

Avoid the following:

- Speed lower or higher than permitted limit
- Very quick start-up
- Too high discharge pressure (gauge pressure)
- Start-up against pressurized system
- Blow-off of air flow by the safety valve when the discharge line is closed
- Excessive discharge temperature
- Soiled intake air filter
- Clogged silencer
- Clogged pipe
- Intake of liquid

### 8.2 Remedial Action

If a problem occurs, refer to the table below for possible causes and remedies. If a problem occurs which is not described in the table, contact our customer service personnel.

Possible cause	Remedy
<b>Poor output</b>	
<ul style="list-style-type: none"> <li>• Air filter clogged</li> <li>• Intake line leaks</li> <li>• Valves/fittings leak</li> <li>• Low speed</li> </ul>	<ul style="list-style-type: none"> <li>• Clean filter, replace cartridge if necessary</li> <li>• Detect leak in line and repair leak</li> <li>• Replace leaking valve/fitting</li> <li>• Raise speed to above minimum level</li> </ul>
<b>Abnormal noise</b>	
<ul style="list-style-type: none"> <li>• Compressor tilt too large</li> <li>• Defective bearing</li> <li>• Wrong speed</li> <li>• Pressure fluctuations</li> </ul>	<ul style="list-style-type: none"> <li>• Keep within max. tilt of 10°</li> <li>• Inform customer service</li> <li>• Adjust speed to within limits</li> <li>• Adjust pressure to within limits</li> </ul>
<b>Compressor does not run at operating gauge pressure</b>	
<ul style="list-style-type: none"> <li>• Pressure gauge reading is wrong</li> <li>• V-belt slips</li> <li>• System leak</li> </ul>	<ul style="list-style-type: none"> <li>• Replace pressure gauge</li> <li>• Check belt tension and adjust if necessary</li> <li>• Repair leak</li> </ul>
<b>Compressed air temperature too high</b>	
<ul style="list-style-type: none"> <li>• Discharge pressure too high</li> <li>• Line clogged</li> <li>• Air filter clogged</li> </ul>	<ul style="list-style-type: none"> <li>• Keep within operating gauge pressure</li> <li>• Remove clog</li> <li>• Clean filter</li> </ul>
<b>Power consumption too high</b>	
<ul style="list-style-type: none"> <li>• Speed too high</li> <li>• Discharge pressure too high</li> <li>• Pressure gauge reading wrong</li> </ul>	<ul style="list-style-type: none"> <li>• Keep within operating speed limits</li> <li>• Keep within maximum permitted operating pressure</li> <li>• Replace pressure gauge</li> </ul>

Possible cause	Remedy
<b>Safety valve blows off air</b>	
<ul style="list-style-type: none"> <li>• Shutoff valve in discharge line is closed</li> <li>• Discharge network is clogged</li> </ul>	<ul style="list-style-type: none"> <li>• Open shutoff valve</li> <li>• Remove clog in system</li> </ul>
<b>Oil pressure at operating temperature &lt; 0.5 bar gauge</b>	
<ul style="list-style-type: none"> <li>• Oil filter clogged</li> <li>• Drive speed too low</li> <li>• Wrong oil grade</li> <li>• No oil or not enough oil in the machine</li> <li>• Machine has more than maximum tilt</li> </ul>	<ul style="list-style-type: none"> <li>• Replace oil filter</li> <li>• Increase drive speed</li> <li>• Change oil and fill oil of prescribed grade</li> <li>• Add oil</li> <li>• Keep machine within maximum tilt</li> </ul>
<b>Oil pressure fluctuates</b>	
<ul style="list-style-type: none"> <li>• Not enough oil filled</li> <li>• Compressor has over-tilt</li> <li>• Wrong oil grade</li> </ul>	<ul style="list-style-type: none"> <li>• Add oil</li> <li>• Keep machine within maximum 10° tilt</li> <li>• Change oil and fill oil of prescribed grade</li> </ul>

If the problem persists, please contact our customer service personnel.

## Contact Us

### Americas

Gardner Denver, Inc.  
Industrial Products Group - Americas  
1800 Gardner Expressway  
Quincy, IL. 62305  
Toll Free: 1-800-682-9868  
Phone: 217-222-5400  
Fax: 217-221-8780

**email: [mobilesolutions@gardnerdenver.com](mailto:mobilesolutions@gardnerdenver.com)**

### France

Gardner Denver France SA  
Division Compresseurs  
42, rue du Montmurier, BP 604  
38070 Saint-Quentin-Fallavier, France  
Phone: +33 (0)474941673  
Fax: +33 (0)474941689

**email: [contact.lyon@gardnerdenver.com](mailto:contact.lyon@gardnerdenver.com)**

### UK Sales & Service

Gardner Denver UK Ltd  
PO Box 468  
Cross Lane, Tong  
Bradford, West Yorkshire  
United Kingdom  
BD4 0SU  
Phone: +44 (0)1274 683131  
Fax: +44 (0)1274 651006

**email: [sales.uk@gardnerdenver.com](mailto:sales.uk@gardnerdenver.com)**

### Australia

Gardner Denver Ind. Australia Pty Ltd  
30 Bearing Road  
Seven Hills  
New South Wales  
2147 Australia  
Phone: +61 2 96207000  
Fax: +61 2 96207955

**email: [hermant.malik@gardnerdenver.com](mailto:hermant.malik@gardnerdenver.com)**

### Germany

Gardner Denver Deutschland GmbH  
Am Dorn 14  
48308 Senden  
Germany  
Phone: +49 (0)253634840  
Fax: +49 (0)25363484010

**email: [info.de@gardnerdenver.com](mailto:info.de@gardnerdenver.com)**

### Spain

Gardner Denver Iberica S.L.  
Calle Primavera, 20  
Poligono Industrial Las Monjas  
28850 Torrejon de Ardoz  
Madrid, Spain  
Phone: +34 (0)916560056  
Fax: +34 (0)916770496

**email: [aurelio.fernandez@gardnerdenver.com](mailto:aurelio.fernandez@gardnerdenver.com)**

### Belgium

Gardner Denver Belgium N.V.  
Luithagen 7A  
Haven 200  
B-2030 Antwerpen  
Belgium  
Phone: +32 (0)3 5415040  
Fax: +32 (0)3 5416509

**email: [info.be@gardnerdenver.com](mailto:info.be@gardnerdenver.com)**

### Netherlands

Gardner Denver Nederland BV  
Barwoutswaarder 3B  
3449 He Woerden  
The Netherlands  
Phone: +31 (0)348410150  
Fax: +31 (0)348418079

**email: [sales.nl@gardnerdenver.com](mailto:sales.nl@gardnerdenver.com)**

### Rest of the World

Gardner Denver Ltd  
PO Box 178  
Springmill Street  
Bradford, West Yorkshire  
United Kingdom  
BD5 7YH  
Phone: +44 (0)1274 718100  
Fax: +44 (0)1274 655272

**email: [gdtransportsales@gardnerdenver.com](mailto:gdtransportsales@gardnerdenver.com)**

For additional information, contact your local representative or

The logo for Gardner Denver, featuring the word "Gardner" in a large, bold, black sans-serif font above the word "Denver" in a similar font. A thick red horizontal line is positioned between the two words, extending from the left edge of "Gardner" to the right edge of "Denver".

**Gardner Denver Ltd**  
PO Box 178,  
Springmill Street,  
Bradford,  
West Yorkshire, UK  
BD5 7YH

**Tel: +44 (0)1274 718100**

**Fax: +44 (0)1274 655272**

**Email: [gdtransportsales@gardnerdenver.com](mailto:gdtransportsales@gardnerdenver.com)**

**Web: [www.gd-transport.com](http://www.gd-transport.com)**